

SIN AMP 2

Rev.2.Jan.24.2003

Build the Sans Amp GT2. Pads are provided for panel mount switches, wiring will be different depending on the switches used. Off board components except for the potentiometers are not shown on the layout. Trademarks remain property of their owners.

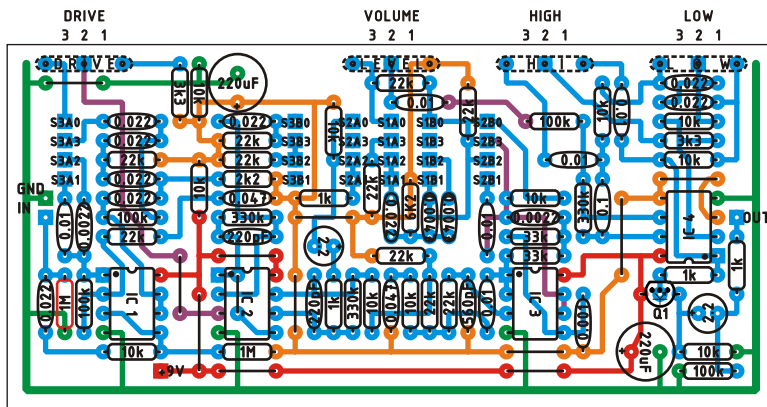

LAYOUT

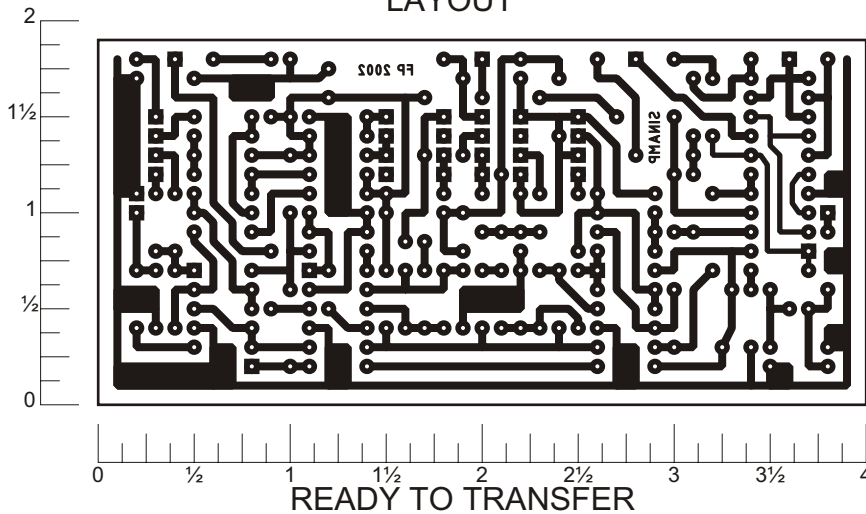

READY TO TRANSFER

Parts List

Resistors

- 4 - 1k
- 1 - 2k2
- 2 - 3k3
- 1 - 6k2
- 11 - 10k
- 10 - 22k
- 2 - 33k
- 4 - 100k
- 3 - 330k
- 2 - 1M

Capacitors

- 9 - 0.022 μ F
- 2 - 0.047 μ F
- 2 - 0.0047 μ F
- 6 - 0.01 μ F
- 1 - 0.1 μ F
- 2 - 220 μ F
- 1 - 560 pF
- 2 - 220 pF
- 2 - 2.2 μ F
- 2 - 0.0022 μ F
- 1 - 0.001 μ F

Pots

- 4 - 100k Lin.

Transistors & ICs

- 4 - TL072
- 1 - BC413B

Switch Settings

- | | | |
|--------------|---------------|----------------|
| S1 = MIC | S2 = MOD | S3 = AMP |
| 1 - Off Axis | 1 - Hot Wired | 1 - California |
| 2 - Center | 2 - Hi Gain | 2 - British |
| 3 - Classic | 3 - Clean | 3 - Tweed |

Switch Wiring

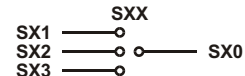

Layout and presentation by Francisco Peña 2001 2002©.
 All rights reserved. Authorization for personal use only.
 any commercial use is forbidden.
 Permission for posting/serving limited to
<http://www.tonepad.com>
 Permission refused for posting from other sites.

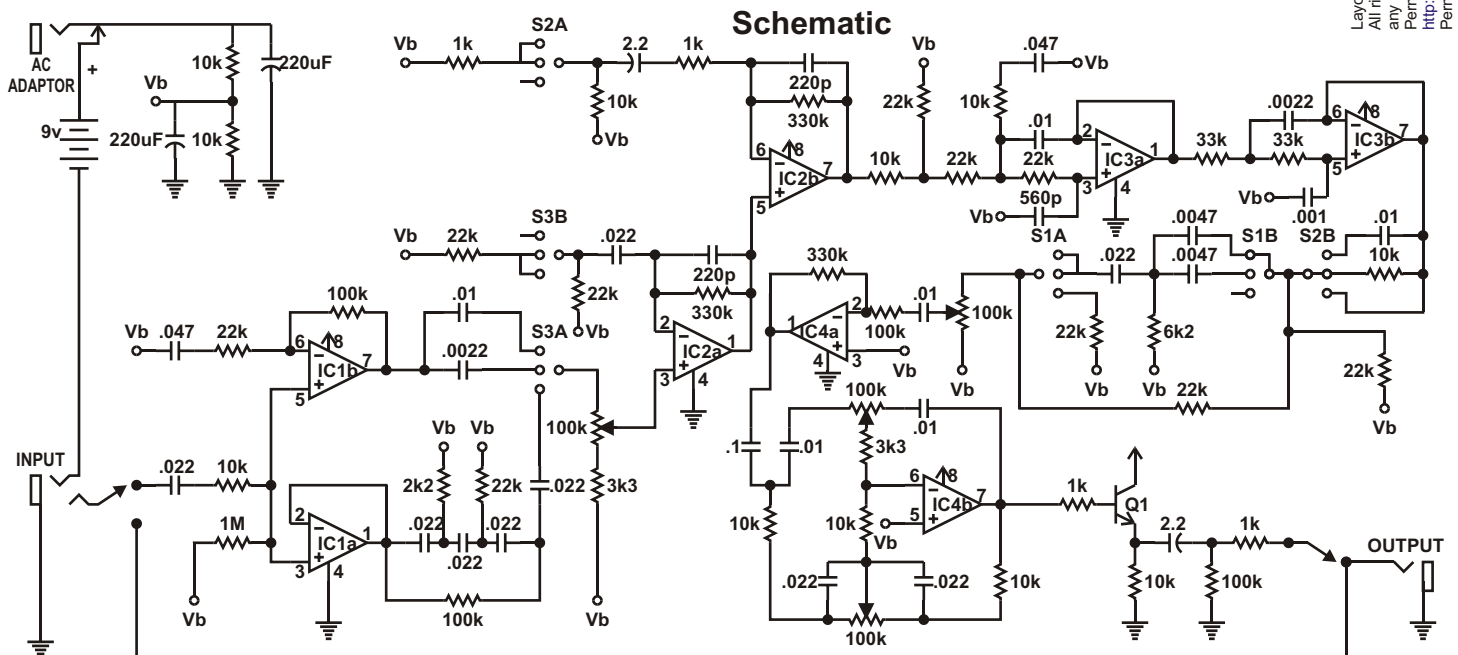

Schematic